

Typical Cross Section
SCALE 1" = 2'

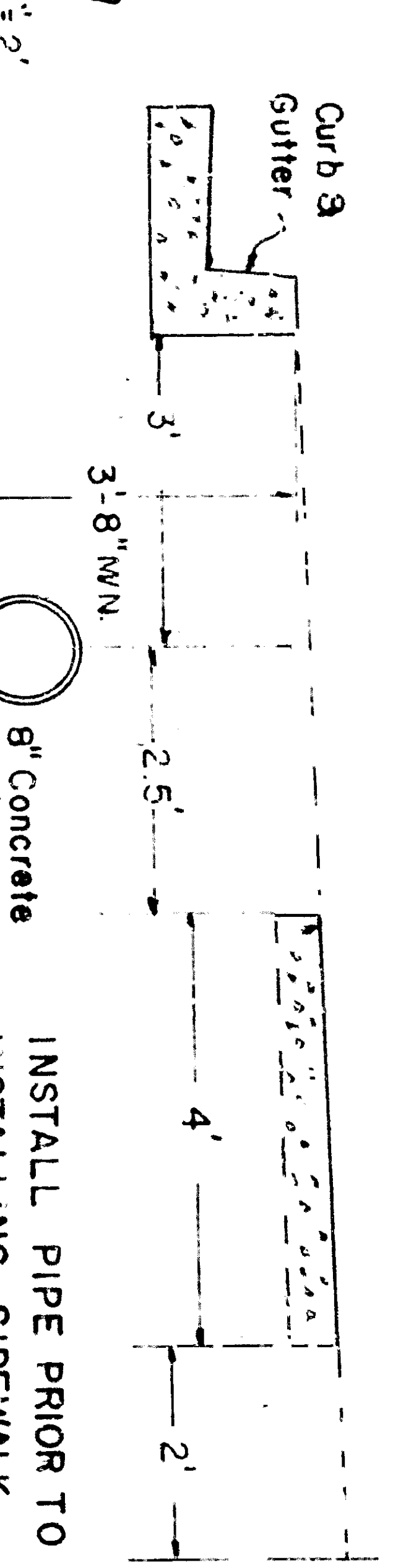

SCALE 1" = 40' HOR
1" = 4' VERT.



Notes
 1. Extra Strength 8" pipe is to be installed under Streets and Alley.
 2. Exact location of south terminus to be determined in field of approximately Sta 3100 Run A.

DEPARTMENT OF ENGINEERING
 CITY OF SAN BERNARDINO
 IRRIGATION LINE REPLACEMENT
 IN RANCHO AVENUE
 TRACTS 5456-5457

SUBMITTED BY NEWTON A. MC NEIL
 APPROVED BY [Signature]
 REGISTERED CIVIL ENGINEER NO. [Number]

REFERENCE DRAWING 2-4-93
 DRAWN BY [Signature]
 CHECKED BY [Signature]
 SHEET [Number] OF [Total Sheets]

NO. [Number]
 DATE [Date]
 BY [Signature]

PLAN
 NO. [Number]
 DATE [Date]
 BY [Signature]

PROFILE
 NO. [Number]
 DATE [Date]
 BY [Signature]

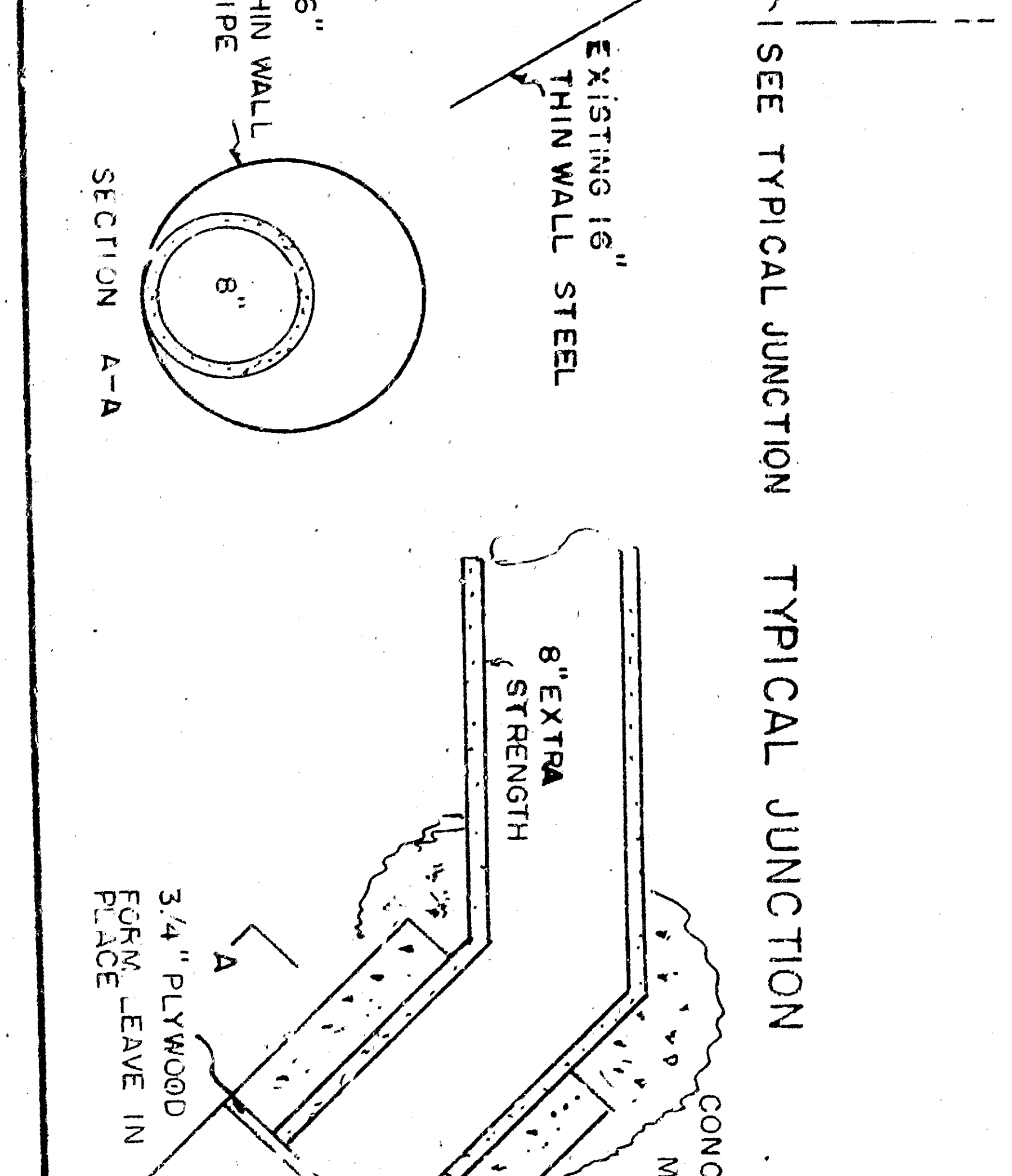
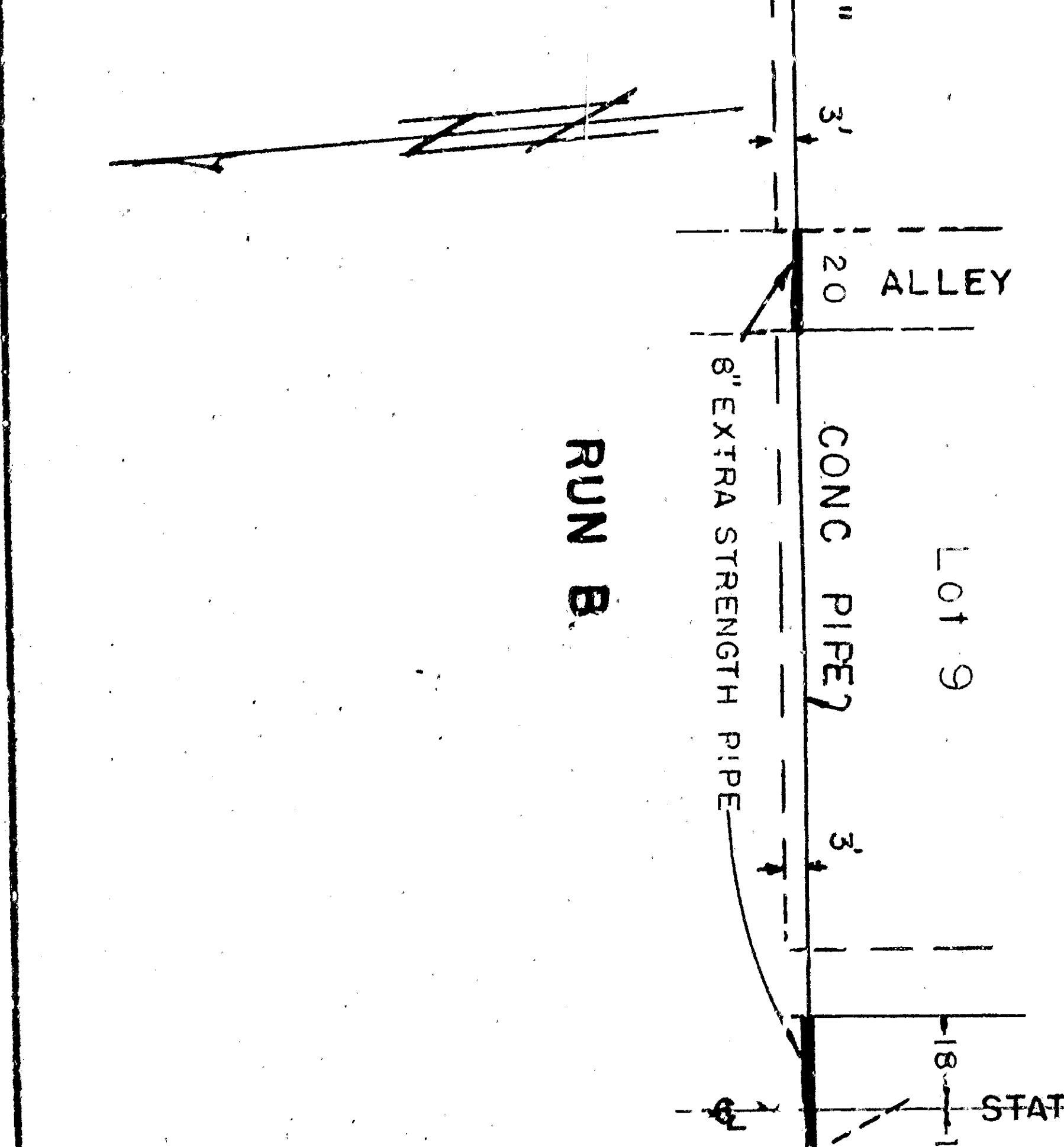
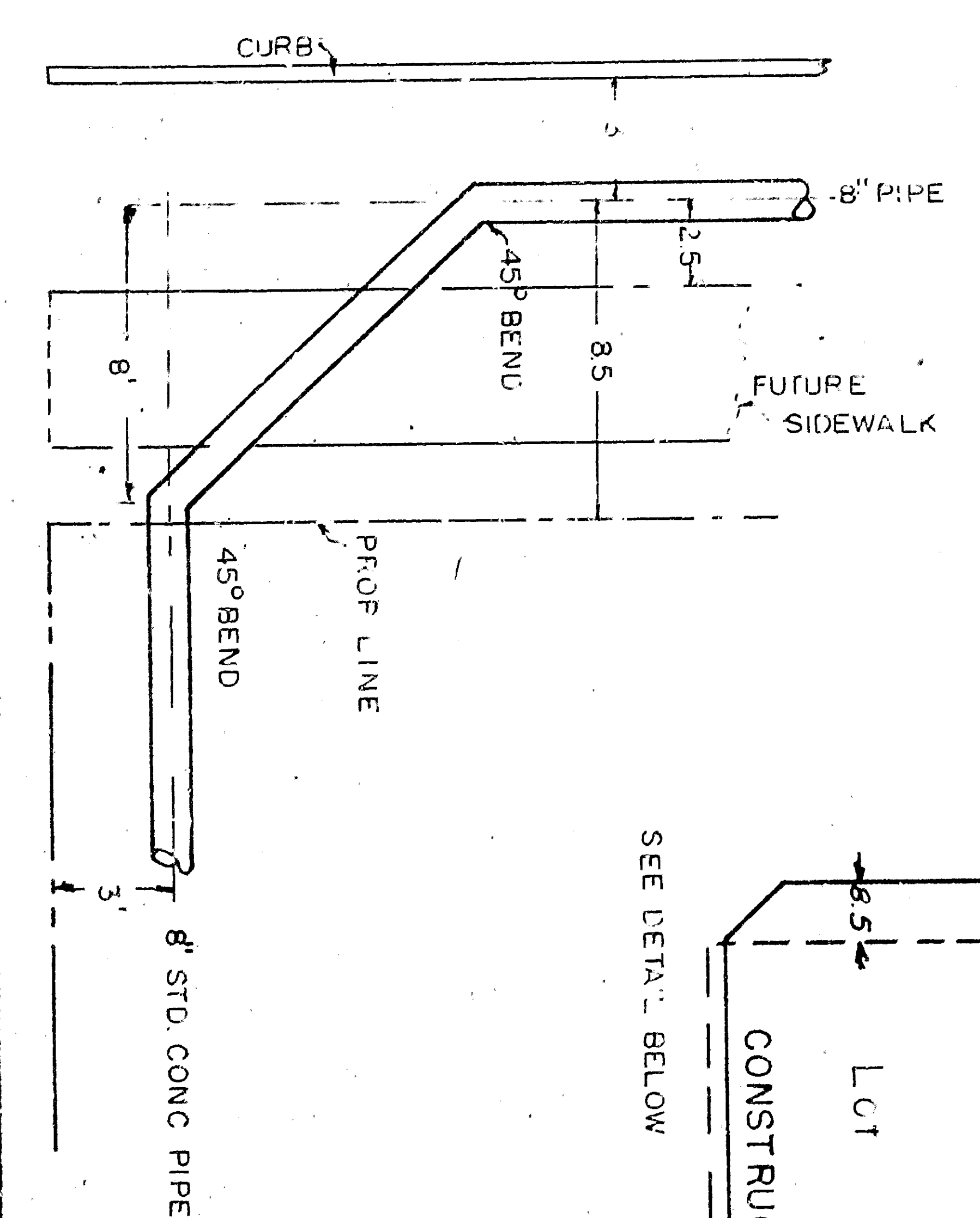

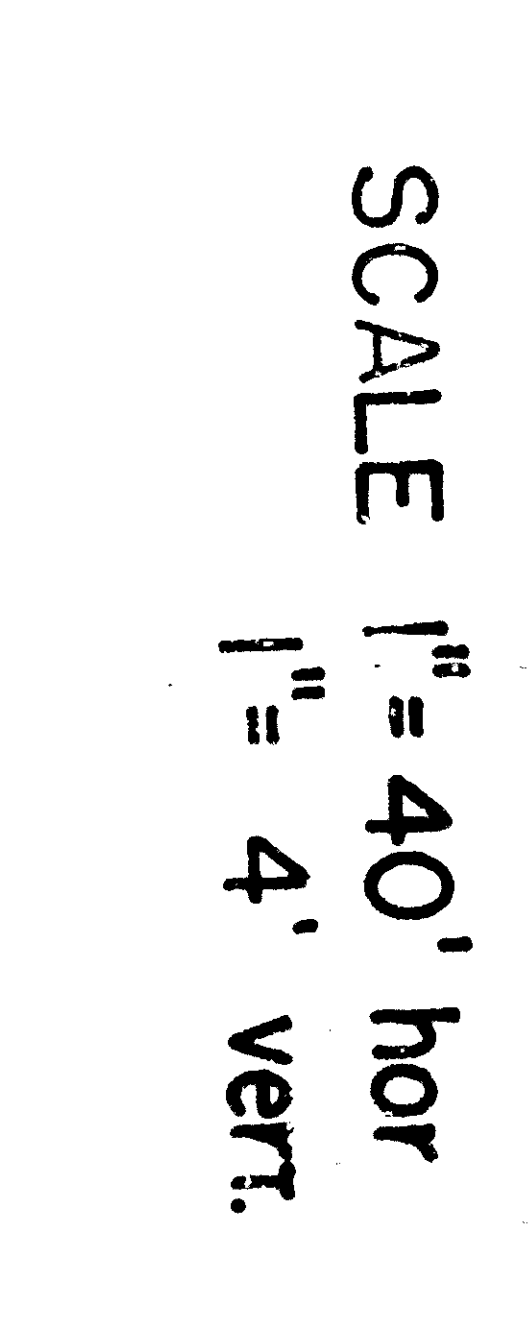
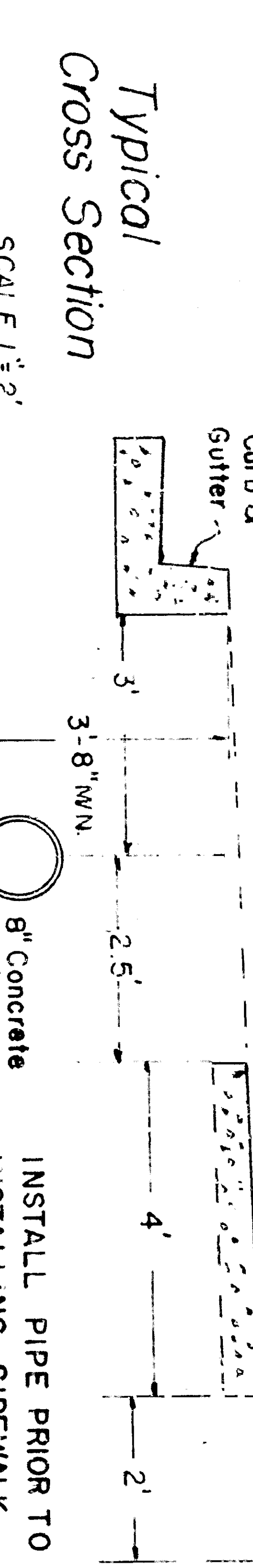


Notes:
 1. Extra Strength 8" pipe is to be installed under Streets and Alley.
 2. Exact location of south terminus to be determined in field of approximately Sta 3100 Run A.

DEPARTMENT OF ENGINEERING
 CITY OF SAN BERNARDINO
 IRRIGATION LINE REPLACEMENT
 IN RANCHO AVENUE
 TRACTS 5456-5457

REGISTERED CIVIL ENGINEER NO. 18
 REGISTERED CIVIL ENGINEER NO. 18

NO.	DATE	BY	REVISION
1			
2			
3			
4			
5			
6			
7			
8			
9			
10			
11			
12			
13			
14			
15			
16			
17			
18			
19			
20			
21			
22			
23			
24			
25			
26			
27			
28			
29			
30			
31			
32			
33			
34			
35			
36			
37			
38			
39			
40			
41			
42			
43			
44			
45			
46			
47			
48			
49			
50			
51			
52			
53			
54			
55			
56			
57			
58			
59			
60			
61			
62			
63			
64			
65			
66			
67			
68			
69			
70			
71			
72			
73			
74			
75			
76			
77			
78			
79			
80			
81			
82			
83			
84			
85			
86			
87			
88			
89			
90			
91			
92			
93			
94			
95			
96			
97			
98			
99			
100			